

FLOOR-STANDING COOKER H500

Project
Rev.:
Zone:
Location:



CODICE
CR0998669

MODELLO
FOGV505

SERIE
SERIE 600

GENERAL CHARACTERISTICS

A line of small-sized cooking equipment designed for those who, even in small spaces, do not want to give up great performance. Made of AISI 304 18/10 stainless steel, finely finished with Scotch Brite satin finish, it has rounded edges and large capacity enclosures; it has 600/650 mm depth and modular width of 400/600/700/800/1000 mm; the series is completed by open, armored or refrigerated base supports.

The equipment is easily modular to one another until it forms a compact, gap-free whole thanks to a leak-covering profile that provides protection against leakage and thus maximum hygiene. High chimneys, ergonomic knobs mounted on a sloping dashboard for easy visibility, give the range ease of use from the first approach.

All models are CE approved.

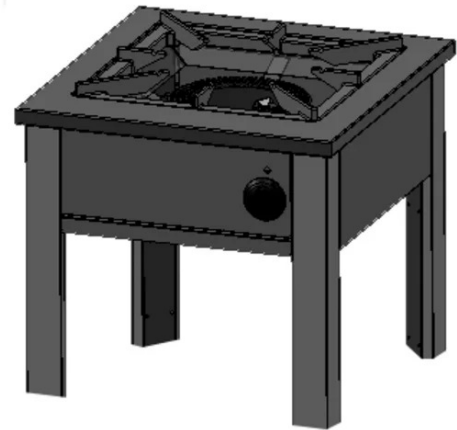

MODEL SPECIFICATIONS

TECHNICAL SPECIFICATIONS

FLOOR-STANDING COOKER H500

Project
Rev.:
Zone:
Location:



CODICE
CR0998669

MODELLO
FOGV505

SERIE
SERIE 600

Technical Information

SPECIFICATION	DATA
MATERIAL	CR0998669
DEFINITION	FOGV 505 12,5Kw FORNELL. 1F H=500
COMMERCIAL LINE	FORNELLONI
SUPPLY	GAS
DIM. WIDTH	590 mm
DIM. DEPTH	630 mm
DIM. HEIGHT	500 mm
NET WEIGHT	30.4 Kg
VOLUME (net)	0.186
PACKAGE LENGTH	690 mm
PACKAGE WIDTH	710 mm
PACKAGING HEIGHT	570 mm
PACKAGE VOLUME	0,279 m3
GROSS PACKING WEIGHT	40.4 Kg
GAS POWER	12,50
GAS POWER (G25.3/25mbar)	11,50
CERTIFIED MODEL	FOGV 50

FLOOR-STANDING COOKER H500

Project
 Rev.:
 Zone:
 Location:



CODICE
CR0998669

MODELLO
FOGV505

SERIE
SERIE 600

MISURE IN cm - DIMENSIONS IN cm - ABMESSUNGEN IN cm - MESURES EN cm
 MEDIDAS EN cm - MATEN IN cm - DIMENSIONES EN cm

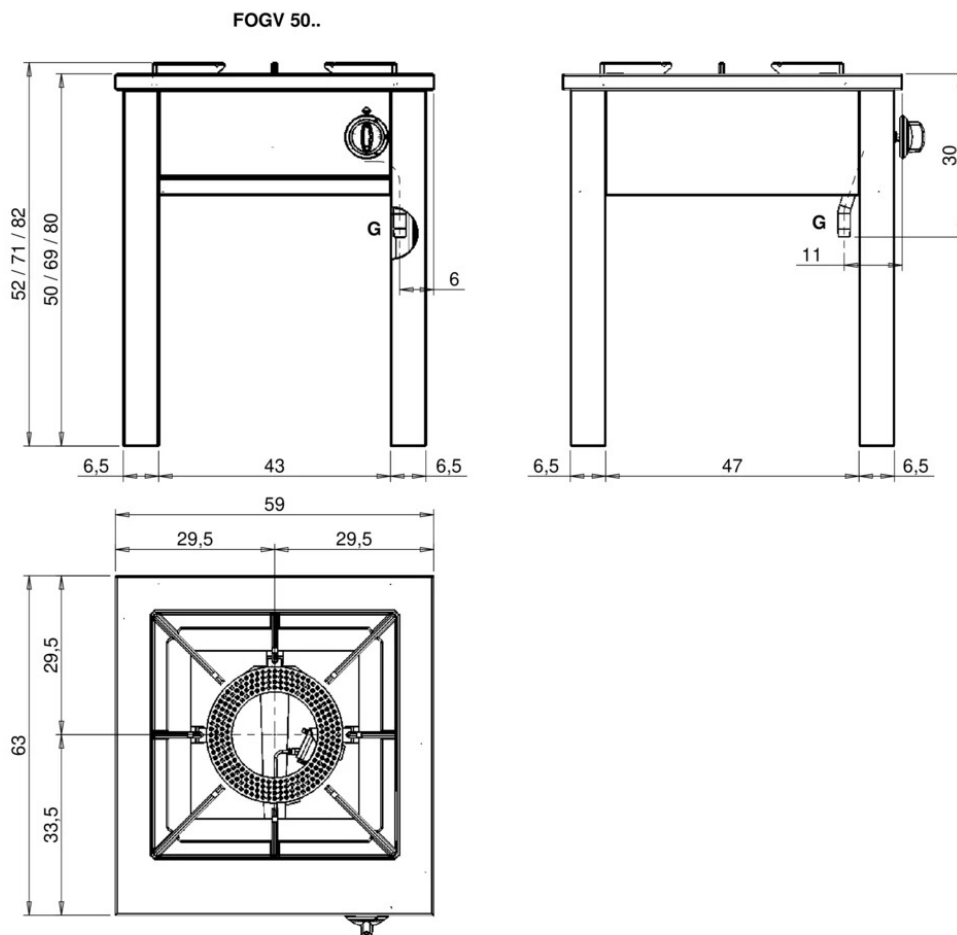

Legenda - Legende - Key - Légende - Leyenda - Legenda - Legenda

E Pressacavo entrata linea elettrica - Stopfbuchse - Electric cable stress relief - Presse étoupe de câble él - Pisacable - Elektrische kabelwartel - Entrada cabo eléctrico	G Arrivo gas - Gasanschluss - Gas connection - Arrivée gaz - Union de gas - Gasaansluiting - Ligação gás EN 10226-1 R 1/2; EN ISO 228-1 G 1/2 (DK)
S Attacco scarico acqua - Wasserablauf - Water outlet - Vidange de l'eau - Desaguadero - Wateraftapaansluiting - Junção descarga água	H20 Arrivo acqua - Wasseranschluss - Water inlet - Arrivée eau - Union de água - Wateraansluiting - Junção alimentação água
S1 Scarico vasca - Wannenabflussrohr - Pan outlet - Vidange du bac - Descarga cuba - Water toevoer - Descarga da cuba	A1 = Calda - Heiss - Warm - Chaude - Caliente - Warm - Morno A2 = Fredda - Kalt - Cold - Froid - Fria - Koude - Frio
S2 Valvola di depressione - Anti-depression valve - Unterdruck ventil - Soupape de dépression - Válvula de depresión - Onderdrukklep - Válvula de depressão	
S3 Scarico acqua intercapedine - Wasserablauf Zwischenraum - Jacket water drain Evacuation eau double envelope - Descarga de agua intersticios - Afvoer water tussenruimte - Descarga de água na marmita com Sistema de aquecimento indirecto	
S4 Scarico - Abflussrohr - Drain - Tuyau d'évacuation - Tubo de drenaje - Aftapbuis - Tubulação de dreno	L Rubinetto di livello - Level tap - Wasserhahn - Robinet de niveau - Grifo de nivel - Niveaakraan - Torneira de nível

FLOOR-STANDING COOKER H500

Project
Rev.:
Zone:
Location:



CODICE
CR0998669

MODELLO
FOGV505

SERIE
SERIE 600

ACCESSORIES

CODE	MODELLO	DESCRIZIONE
2520821	31SG	L45 COOKER SUPPORTS
2520822	32SG	L90 COOKER SUPPORTS