

People structures, systems design and the portfolio

Portfolio – interface between the line hierarchy and the virtual delivery structures



- Strategic
- Tactical
- Road map
- Money
- etc.

Wholeness

- Tactical/Operative
- Infrastructure
- Systems design
- Architecture
- Systems Test
- Technology
- Total UX
- Tools
- etc.-

Development of components including the UX component

- Operative
- User friendly
- Appearance
- "I like"
- Fun
- etc.

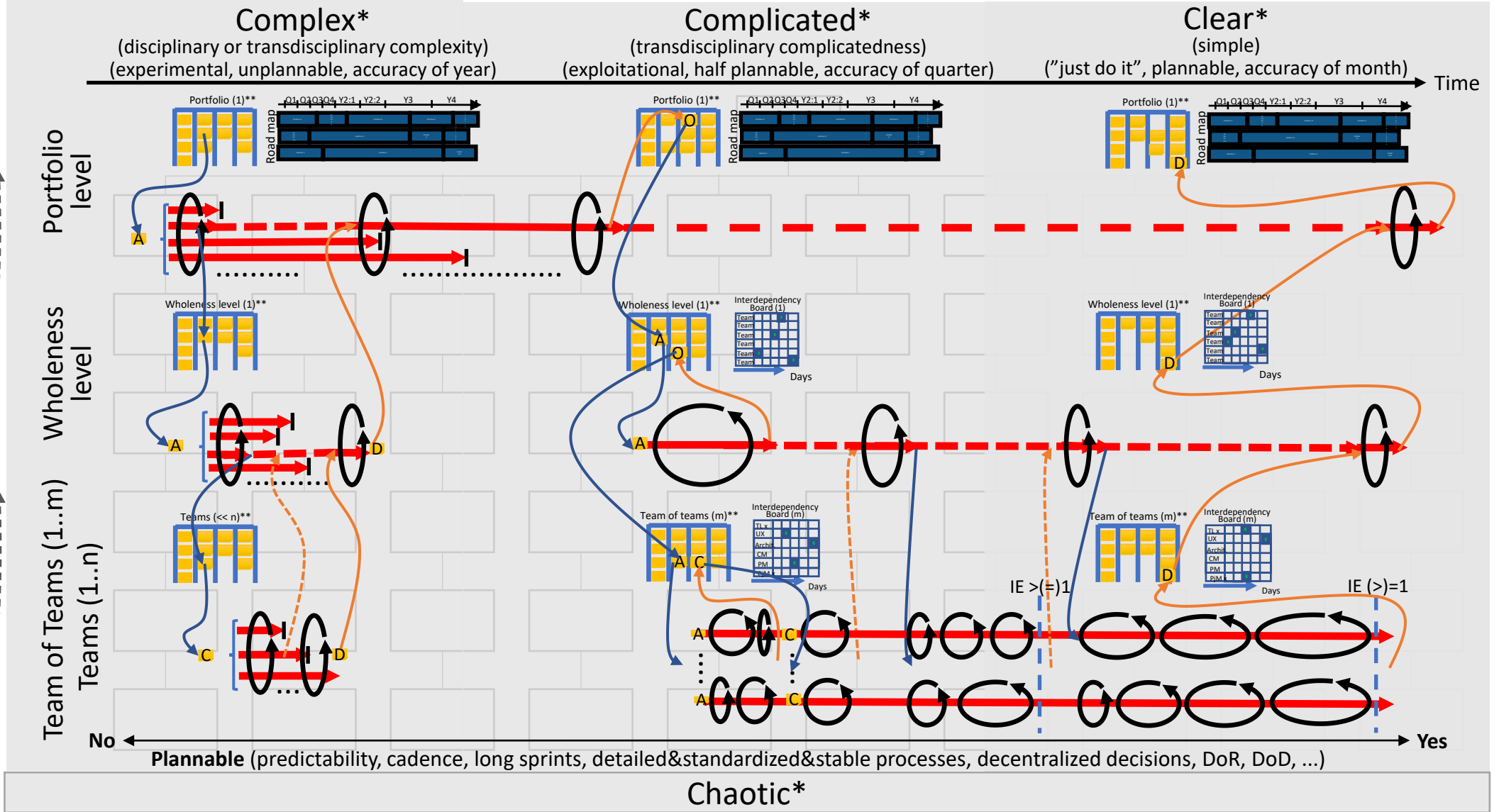

Plannable (predictability, cadence, long sprints, detailed&standardized&stable processes, decentralized decisions, DoR, DoD, ...) Yes

Chaotic*

Version: 0.9981

Iteration/feedback loop (duration: complex: hours/days/weeks, complicated: days/weeks/months, obvious: weeks/months/quarters)

*within the Cynefin™ Framework
 **Visualization (e.g. Kanban board columns):
 - Portfolio/WL: Analyze, On-going Test/Done
 - ToT - Analyze, Code, Test/Done
 ***multiple (and contrary) when Complex

— Concept***
 → Closed concept
 - - - Support
 ↪ Perform ↪ Ready ↪ Exploit, Experiment

IE – Integration Event
 WL – Wholeness Level
 ToT – Team of teams
 ■ Activity (splitting into details not visualized)
 ■ Interdependency (between ToTs and/or teams)
 ■ Initiative